

Safetech Snap Back Dock Shelter - S-3200

The Safetech Snap Back Dock Shelter S-3200 is designed to service a wide variety of trailer sizes and types, while providing full trailer access during the loading process. A gravity-biased, flexible frame yields to misaligned trailers, preventing costly building and shelter damage. It also provides a cost effective and energy saving solution for a number of different applications where temperature control is not critical.

Features

1. Roll-formed galvanised steel framing (5-year limited warranty).
2. White UV-resistant vinyl-coated fabric allows natural light to enter the dock area.
3. Overlapping layers of fabric provide more wear resistance against the sharp corners of the trailer, extending the life of the shelter.
4. Flexible fiberglass stays ensure that head and side curtain pressure is maintained on the truck body while compressible neoprene cords conform to the vehicle's irregular perimeter.
5. High-visibility guide stripes assist drivers with proper positioning of trailer.

Construction / Frame

Compression is not required to form a seal, pressure on the exterior of the building is eliminated. The retractable frame prevents any damage in the event of vehicle misalignment.

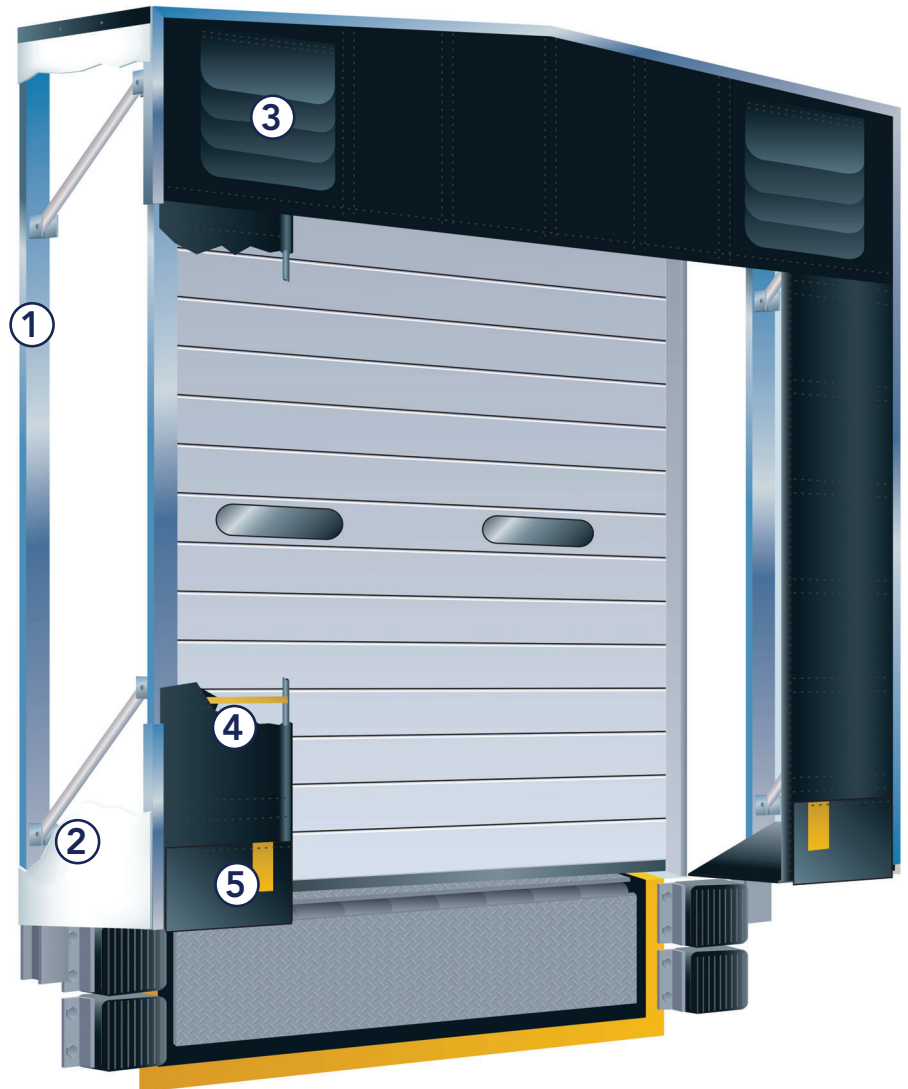

How It Works

As the trailer approaches the loading dock, if misalignment occurs, the Snap Back frame moves upwards and back preventing costly damage to the building and shelter. Once loading / unloading is completed a gravity biased design returns the shelter to its original position ready for the next operation.

