



# Door Solutions



Australian designed, locally manufactured  
**Industrial and Commercial Door Solutions from Safetech**

# Trust the doors Safetech trusts

Safetech has sold, installed and serviced industrial roller and sectional doors for many years.

We know how important it is to have a door that is reliable and durable.



## When a door fails our lifts fail.

For a long time Safetech bought other suppliers roller doors for use in our hoists and lifts.

Sadly, we couldn't find one that met our performance standards.

Problems we experienced were:

- Low duty cycles
- Slow speed
- Easily damaged in normal use
- Limited after sales support

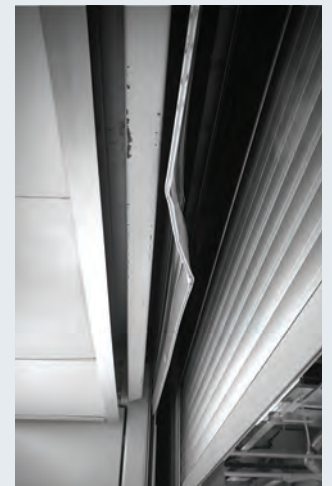

*Avoid this happening*

## Our solution?

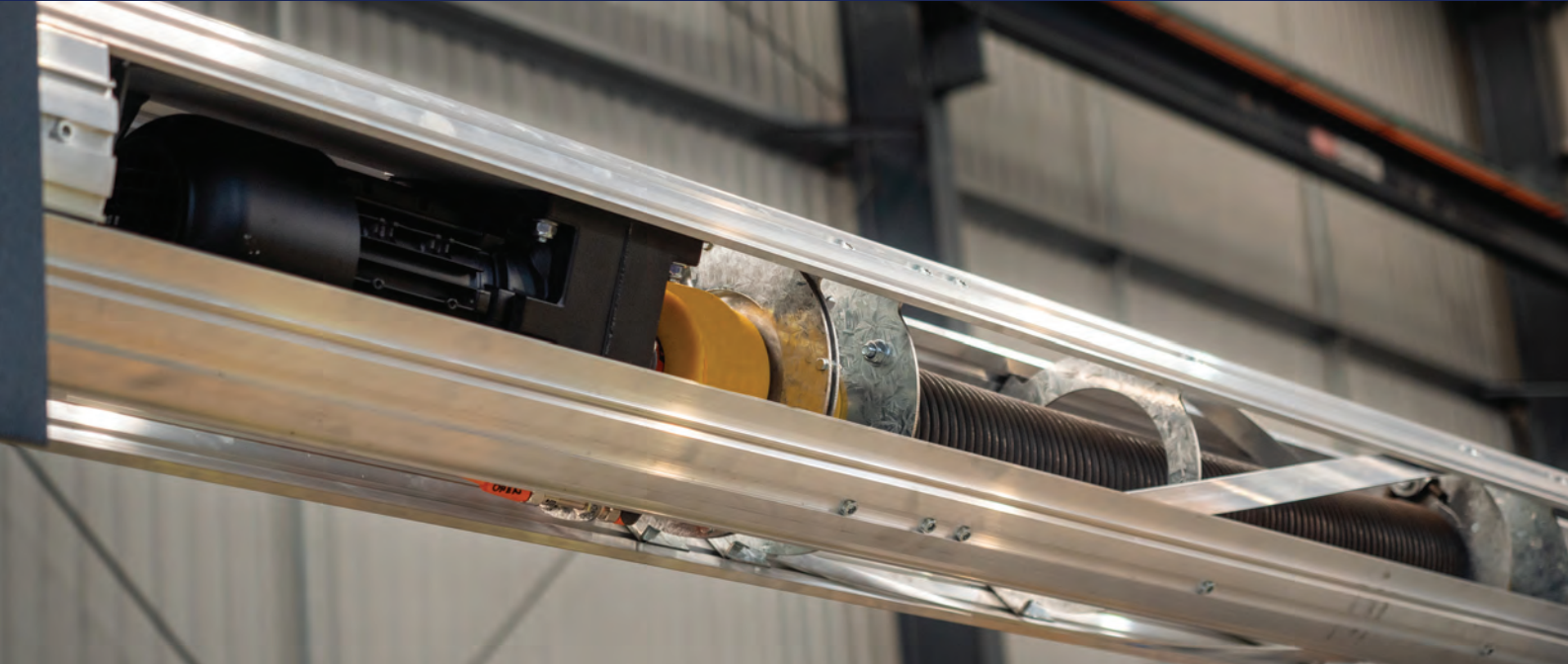

### We designed and built our own doors

Our engineering team designed a door to exceed our highest expectations.

- 100% duty cycles
- Increased durability
- 50,000 plus cycles
- 2x normal roller door speed
- Compact design, internal drive
- Affordable

### The Result

Safetech doors provide superior performance and durability for your factory, warehouse or garage.

The faster door speed reduces the risk of impact damage when loading with pallet trucks, stillages or trolleys

High duty cycle reduces repair and maintenance risk

Supported nationally

### See the difference!

Experience the speed of our DuraFast roller door at one of our showrooms or online.

Search 'DuraFast Roller Door' on YouTube.



# Roller Doors

## Roller Door

### Safetech designed and installed

- 6 second opening/closing speed
- Durable 100% duty cycle
- Flexible cladding options
- Custom widths and lengths available
- Face or recessed mounting options



## Nested Roller Door

### No compromise on door height.

Durafasts unique design recesses the drum and slats in a durable housing mounted between the floor and lift shaft.

Designers can lower roof height without compromising door opening height.

Door enclosure tough, durable, able to withstand high rollover loads

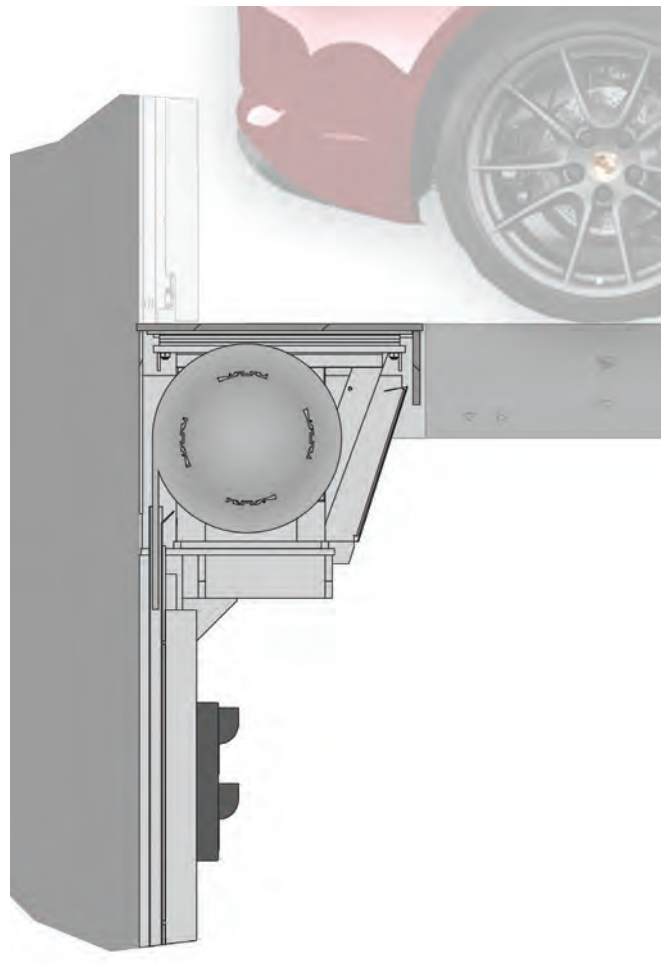

# Sectional Doors

## Sectional Overhead Door

**Popular with private residents and architects who want to fully customise the external look of a building.**

The additional headroom and strength of the available motor allows for more creative freedom when choosing various cladding options.

Safetech offer a range of standard cladding options, but we are happy to consider custom designs in conjunction with architectural requirements.



## Heavy Duty Security Doors

**We offer a range of door solutions for dock environments and secure facilities.**

Durable panel configurations that can be applied to both new and existing developments.

Including:

- Triple layer insulation
- Durable, secure cladding options



# High Speed Roller Door Range

## DuraFast - A game changer in the industry

The Safetech designed DuraFast roller door is one of the latest models in our product line that has halved the industry standard in opening and closing times. Our product also far exceeds our competitors durability by offering proven 100% duty cycles and unprecedented cycle counts.

### Internally mounted drive motor

- Lower profile that maximises door opening height.
- Evenly distributed torque across the drum, improving durability.
- Standard slat mounting specifications, allowing this to be a direct replacement for most existing doors.
- Custom widths and lengths available.
- Lifetime warranty.

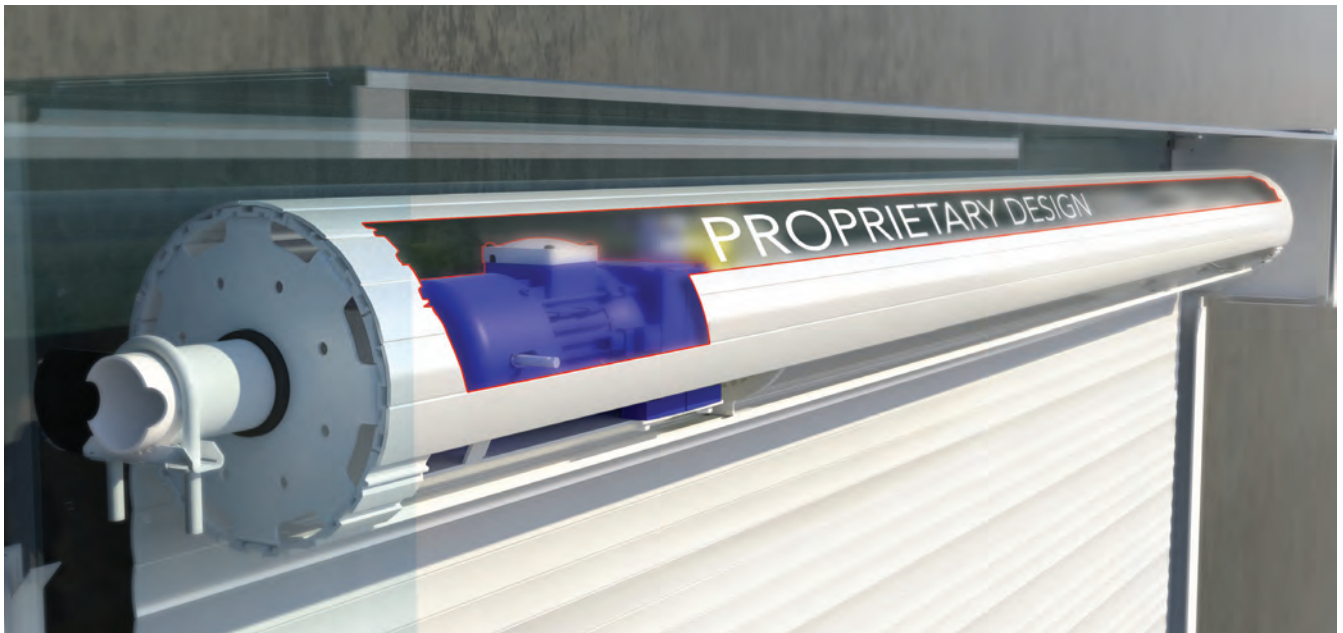

## DuraMax - The large high speed roller door

- 100% Duty cycle.
- Clear door opening (CDO) range of up to 5m wide and high.
- 5 second opening time on 2100mm high CDO.
- 12 second opening time on 5000mm high CDO.
- Aluminium door curtains.
- Optional steel curtains.



# Internal Doors & Facility Access Packages



## Professional, secure access

Safetech lift control systems are intuitive and of a high quality, providing a professional and easy to use interface for our Safetech lifts and hoists.

This system does not need a lift or hoist to work, meaning our door controls can be installed in isolation to provide secure facility access.



## Intuitive controls

Interacting with your door doesn't need to have an industrial feel.

We have a range of user controls available that match the high end finish of any showroom, residence or commercial building.

## Internal automation

Using our photoelectric sensors and lock-out facilities, our high speed roller doors can be installed for rapid and secure transit between internal building sections.

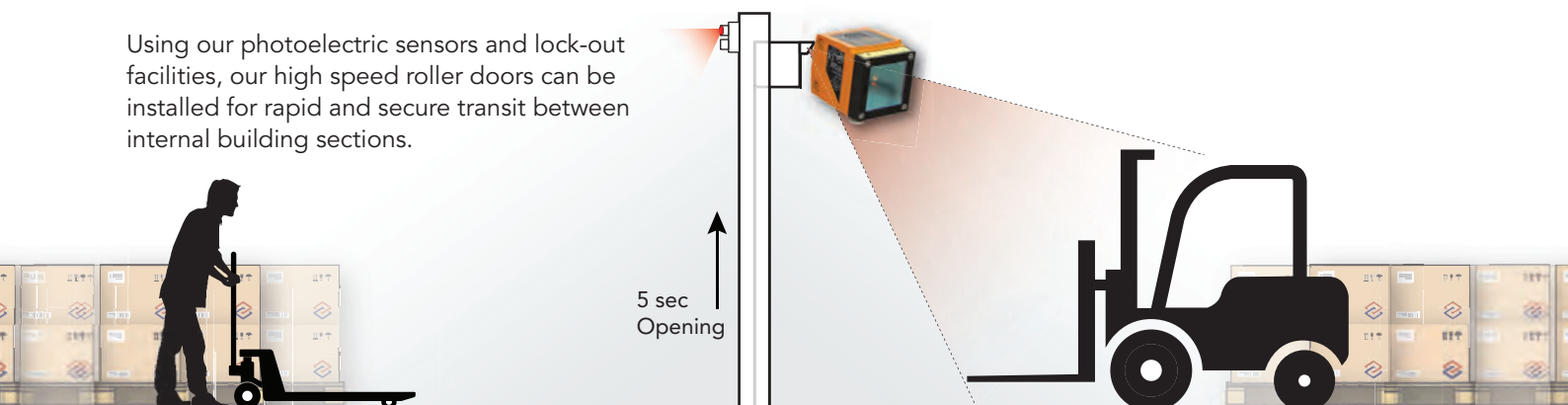

# Choosing the Right Roller Door

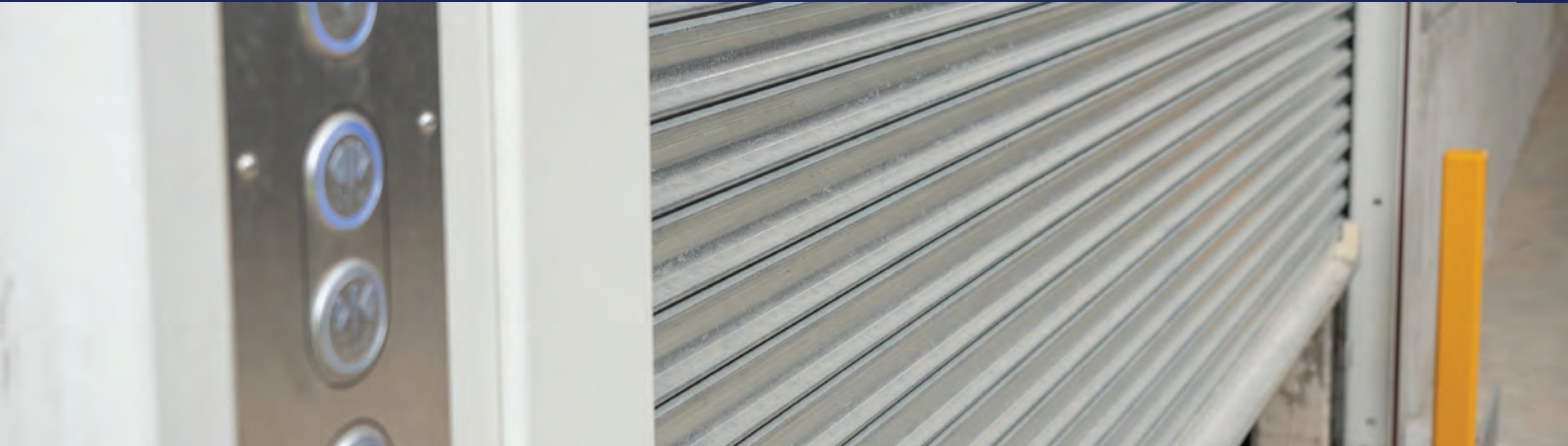

The DuraFast and DuraMax roller doors fit a wide range of openings. The DuraFast has become mandatory in high cycle retail outlets. Whilst our DuraMax range has become popular within loading dock environments.

Use the table below to see what will suit your application.

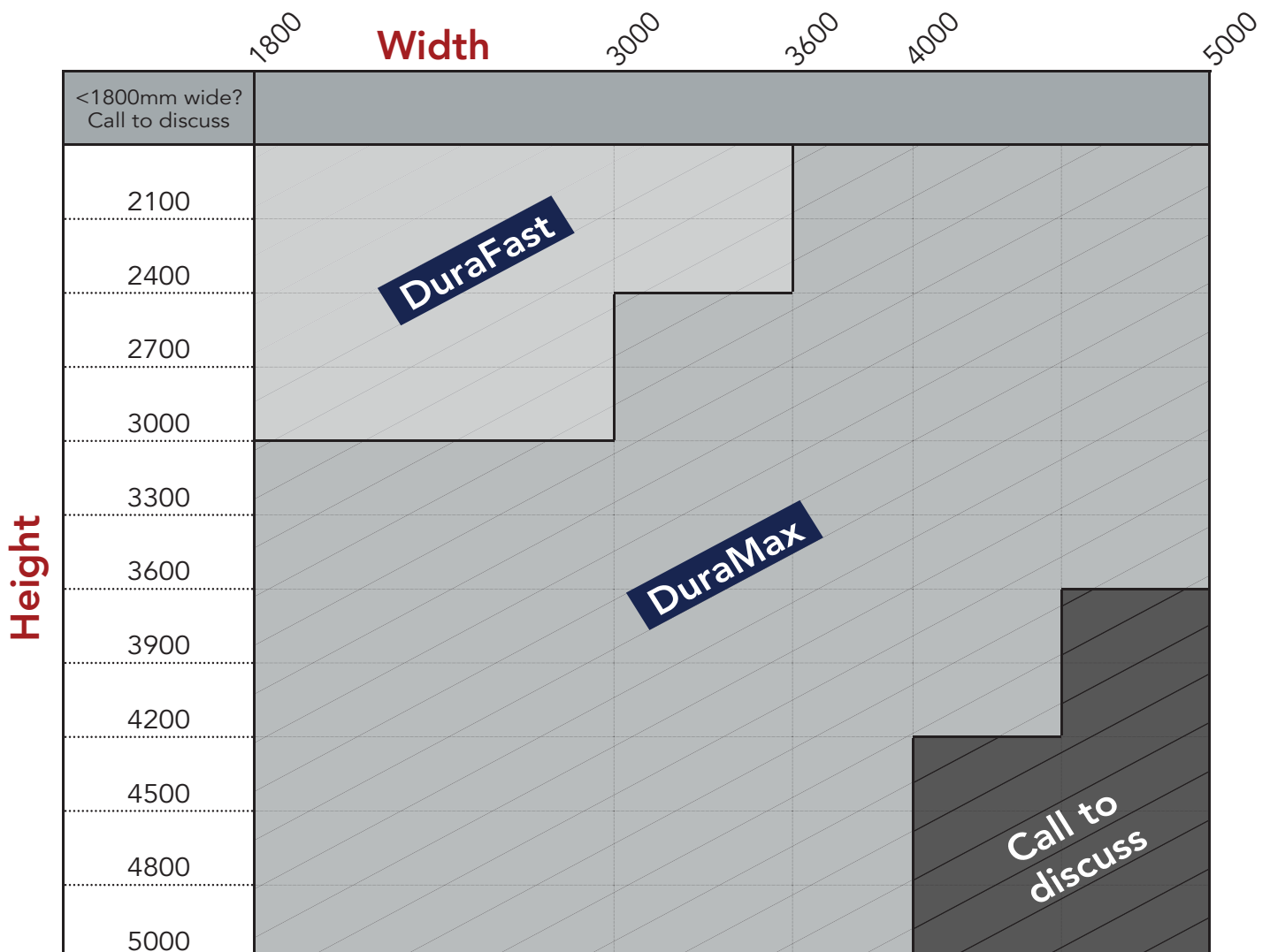



# Overhead Doors

## From our trusted partners

Insulated, transparent and ventilated sectional door options available in various colours for all applications.



## Integration

Safetech ensures overall system installation and integration. Installing a sectional door with your dock leveller/lift means they are integrated for optimum functionality. Locking out the door so that it will not close until the leveller is returned to its home position, and locking out the leveller until the door is opened ensures operation in the correct sequence. (Note that sequencing is optional).

## Options

- Chain operation over ride
- Photo sensors
- Bump edge
- Vision panels
- Remote controls
- Full dock equipment integration panels

## Architecturally sensitive design

Safetech appreciates that the first thing a customer interacts with is the door. Due to this the appearance of the cladding needs to match the finish and character of the rest of the building. The overhead sectional door structure allows for cladding options like glass, timber and other custom textured options.

# Cladding - Slat Options

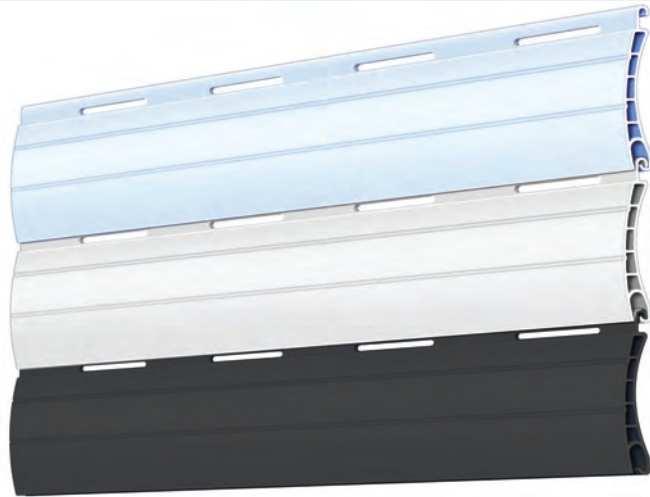

## Aluminium Slats

A range of colours and finishes to suit your specific design

- Standard aluminium
- Powder coated
- Heavy duty series for external areas
- High wind loading



## Perforated Slat options

For visibility, light and security

- Up to 32% of clear surface area for increased ventilation and air flow
- Save on secondary ventilation shaft



## Custom options

With our expertise in integration, we can work with some specialist manufacturers on unique and bespoke door installations.

- Timber cladding
- Corten steel
- Custom profiles
- Glass

# Triple Layer Insulated Sectional Doors



## Colours

- Commercial White - Standard
- Commercial Grey - Optional
- Commercial Brown - Optional



The Amarr 2742 Model is a high insulation rated door for designed exclusively for commercial and industrial sectional overhead door market.

It's construction is a foamed-in-place polyurethane insulation which creates a strong monolithic panel that is highly energy efficient.

## Design

Designed for use in commercial installations the Amarr 2742 is the perfect completion to a dock installation, or can be installed separately for your cool room application.

The pencil groove construction separates the inner and outer skins so that heat transfer is minimised through the covering. This is important to avoid condensation on the outer surface. The foamed-in-place polyurethane insulation provides a door panel of 51mm.

## Triple-layer

**Steel + Insulation + Steel**

**Track:** All doors come standard with 76mm track in Standard Lift, High Lift or Vertical Lift. Custom track configurations are also available.

**Hardware:** Includes galvanised steel hinges and galvanised steel track brackets. All rollers have minimum 10-ball bearings.

**Springs:** Torsion springs are oil tempered, helical wound and custom computed for each door for a minimum 10,000 cycle life.

\*Safetech supplies as standard 50,000 cycle life springs. (Subject to minimum door width and track type. May be reduced on smaller doors, and larger doors with vertical lift track).

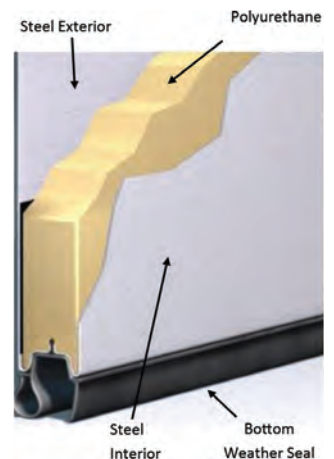

## Integration

Safetech ensures overall system installation and integration. Installing a sectional door with your dock leveller/lift means they are integrated for optimum functionality. Locking out the door so that it will not close until the leveller is returned to its home position and locking out the leveller until the door is opened ensures operation in the correct sequence. (Note that sequencing is optional).

## Powered Jackshaft Operator



This door is optimised for dock installations with the inclusion of powered operation. The Maneras Operator comes standard with momentary up and stop button, and constant pressure down control.

# Further Information

Contact your local Safetech sales representative for a copy of our Vehicle Lifts, Dock Products, or Freight Hoist brochures.

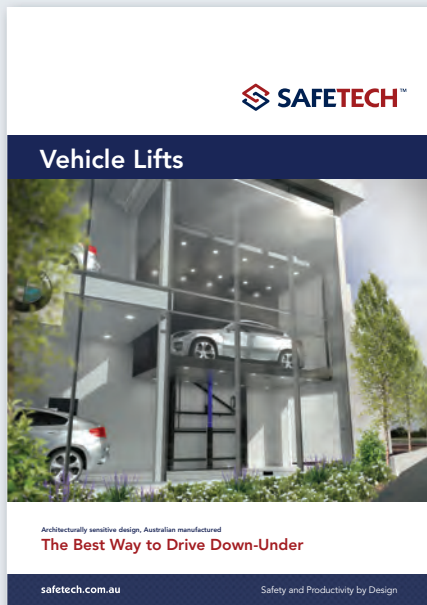

## VEHICLE LIFTS

Australia's best Vehicle Lifts that add value to your building are made by Safetech. Jump on the website or get your free brochure to see for yourself.

- Passenger lift control schemes
- Premium finishes
- High cycle counts
- Heavy capacities
- Custom design options
- Maximised door openings
- 24/7 Service & Support



## FREIGHT HOISTS

The Australian designed Freight Hoist is a staple in the factory and self storage industries.

Safetech can provide personnel or goods only variations for your particular application.



## DOCK PRODUCTS BROCHURE

For more information about our full range of Dock Products, including popular items such as:

- Seals & Shelters
- Wheel and Trailer Restraints
- Pit Boxes
- Control Panels
- Plus much more.

39-45 Della Torre Road, Moe Victoria 3825  
t: 1800 674 566  
e: sales@safetech.com.au